

INJECT RENEWABLES PVT LTD

DG Synchronization Working with Solar System

1. Purpose of DG-Solar Synchronization

DG synchronization with solar allows **both sources** to work **together seamlessly**, optimizing fuel use and solar power without harming the generator or causing system instability.

2. Key Reasons for Synchronizing DG with Solar

2.1. Reduce Diesel Consumption (Fuel Savings)

- Solar power offsets part of the load on the DG.
- As solar takes over part of the load, the DG works at lower fuel consumption.
- Over time, this results in significant **operational cost savings**.

2.2. Avoid Reverse Power Flow to DG

- Synchronization ensures that **solar never feeds power back** into the DG (which can damage it or cause tripping).
- The system monitors **per-phase loads**, and the inverter adjusts output accordingly.

2.3. Maintain System Stability

- Sudden changes in solar generation (like cloud cover) can cause load imbalance.
- A synchronized system dynamically adjusts DG and inverter output to keep voltage and frequency stable.

2.4. Maximize Use of Renewable Energy

- Synchronization lets the system **prioritize solar** while still having DG backup.
- This increases the share of **clean energy** used on-site.

3. Connection Diagram

3.1 Inverter Communication Connection

- Connect the inverter's RS485 communication cable to the Data Logger RS485 Channel 1.
- Ensure correct polarity:
 - A = Positive
 - B = Negative

3.2 DG MFM Communication Connection

- Connect the DG Multi-Function Meter (MFM) RS485 communication cable to Data Logger RS485 Channel 2.
- Maintain the correct polarity:
 - A = Positive
 - B = Negative

3.3 DG Phase Reference to DG Relay

- Provide a single-phase voltage reference to the DG relay from the DG incoming side.
- Reference can be taken from any one phase of the DG.

3.4 Grid Phase Reference to Grid Relay

- Provide a single-phase voltage reference to the Grid relay from the Grid incoming side.
- Reference can be taken from any one phase of the Grid.

3.5 Common Busbar Reference to SMPS

- Provide a single-phase voltage reference to the SMPS (Switch Mode Power Supply) from the Common Busbar (Load Side).
- This ensures the SMPS is powered from the same phase as the system load.

3.6 CT Installation and Connection

- Install the Current Transformers (CTs) at the DG panel incoming side (i.e., the point where DG connects to the system).
- Connect the CTs to the DG MFM (Multi-Function Meter) as per the wiring diagram (refer to Figure 2).

Figure No-1

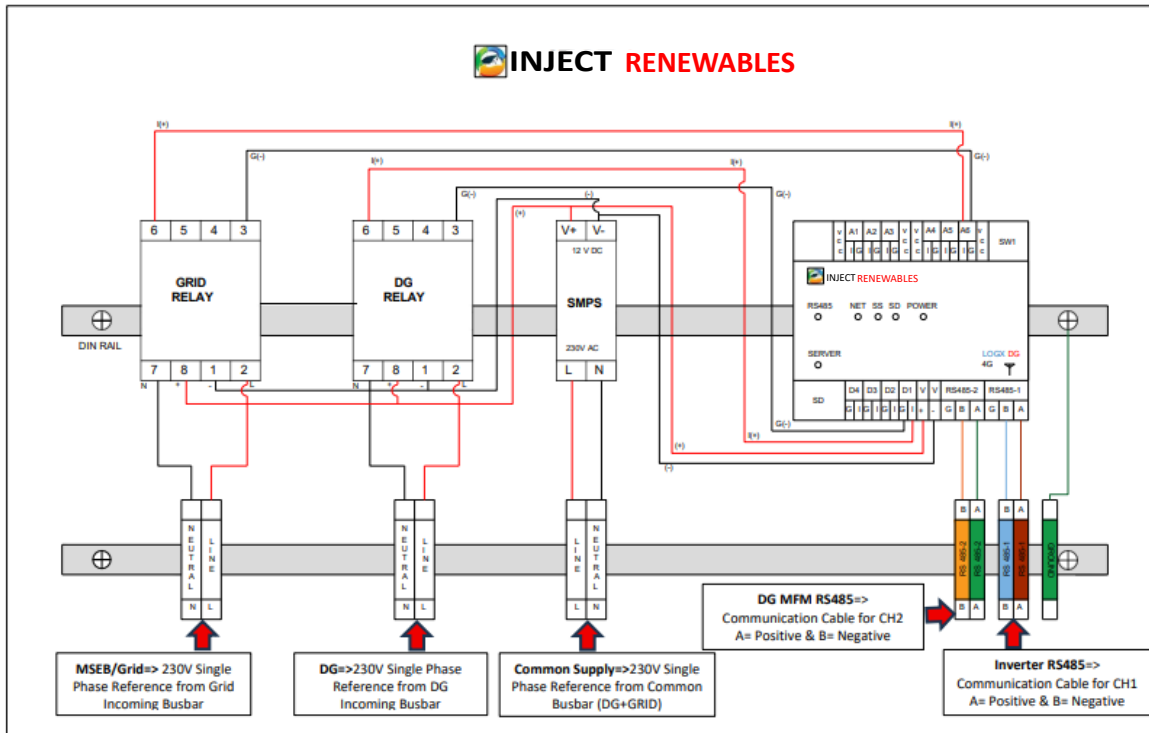
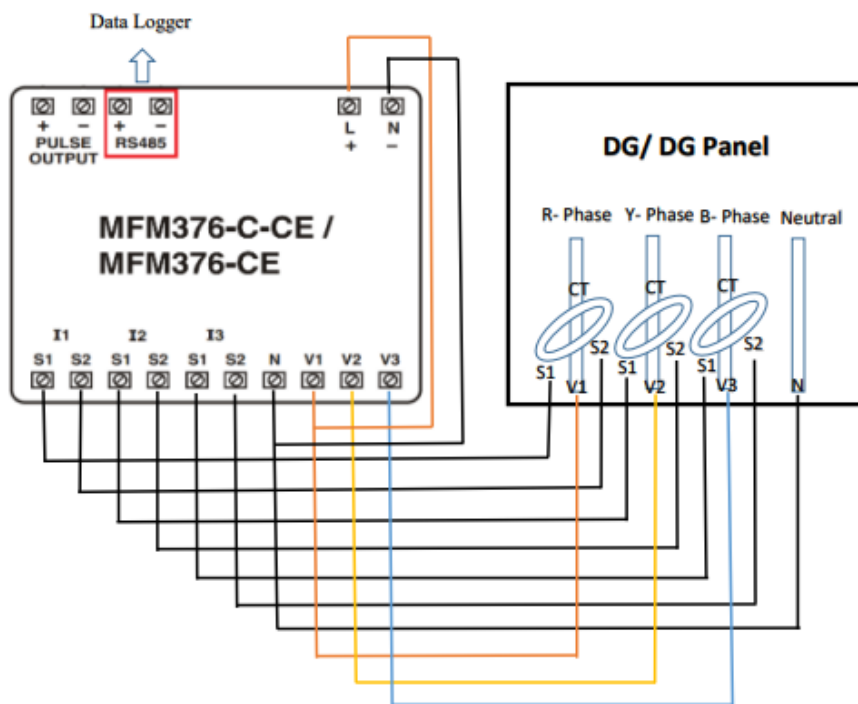

Figure No 2

MFM METER TO DG/DG PANEL CABLE CONNECTIONS DIAGRAM:-

Case-1-



4. DG Synch Working

The system operates in both **DG Mode** and **Grid Mode**.

4.1. Operational Logic (Grid Mode)

In the presence of utility grid supply:

- The inverter operates at **100% capacity**.
- Full solar generation is allowed.
- No phase load detection is necessary in grid mode.

2. Operational Logic (DG Mode)

When the system is operating on DG power (no utility grid available), the inverter operates under specific load-sharing logic based on the load on each phase of the DG.

Step-by-Step Process

DG Capacity= 200KVA

Inverter Capacity= 150kW

1. Phase Load Monitoring:

The controller continuously reads the power output from each DG phase:

- Phase R (L1)
- Phase Y (L2)
- Phase B (L3)

2. Identify Minimum Phase Load:

Among the three phases, the minimum active power (in kW) is identified.

- **Example:**
 - R = 30kW
 - Y = 35 kW
 - B = 40kW
 - **Minimum phase load = kW (Phase R)**
- 30% of DG Capacity = **60 kW**
- When the load exceeds 30% of the DG capacity, the solar inverter begins generating power. If the load is below 30% of the DG capacity, the solar inverter output is limited to 1% of its rated capacity.

3. Inverter Output Control Logic:

DG Load Condition Inverter Output

< 30% of DG Capacity 1% of inverter capacity

≥ 30% of DG Capacity Solar generation enabled based on load (dynamic)

- When the **total DG load** is less than 60 kW, the inverter output is limited to **1%** (approx. 1 kW).
- Once the **total DG load** reaches or exceeds 60 kW, the inverter begins generating power.

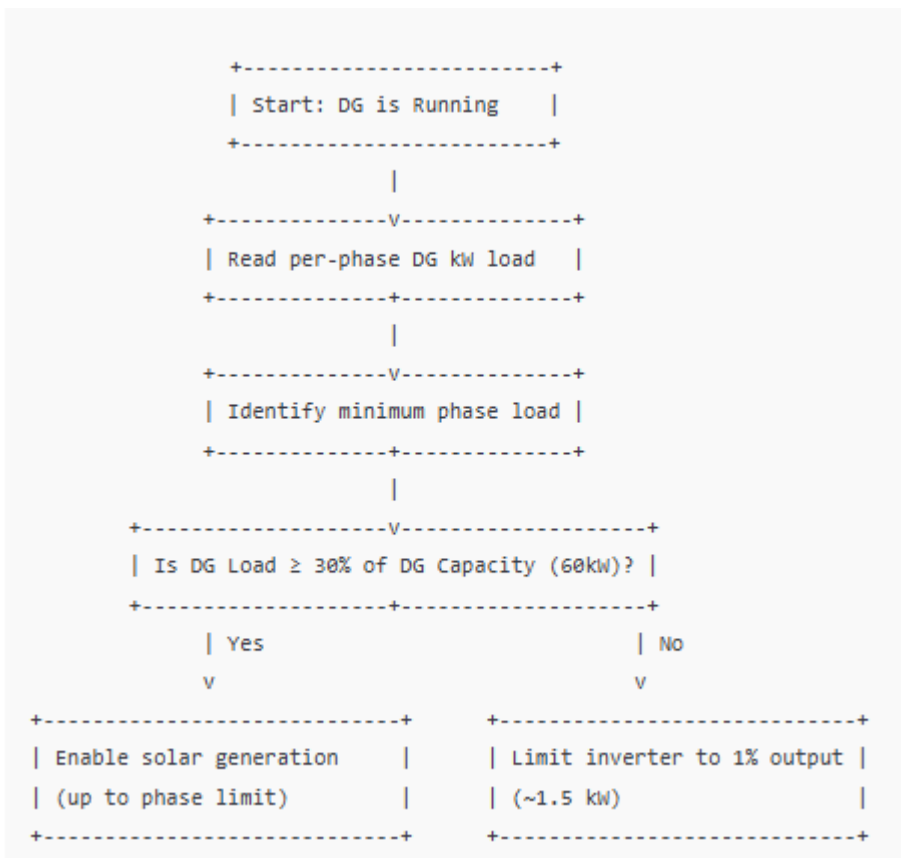

Note: In the event of a communication failure between the inverter and the Data Logger, or between the DG MFM and the Data Logger, the inverter will automatically limit its output to 1% of its capacity to prevent any risk of reverse power flow to the diesel generator.